

A G E N D A

If you need this information in another language or format or disability accommodations, email access@brooklynpark.org or call 763-293-8000.

Si usted necesita esta información en español: 763-315-8000.

Yog xav tau kev pab, thov hu rau 763-424-8000 lawv mam li nrhiv ib tus neeg txhais lus rau koj.

1. CALL TO ORDER/ROLL CALL

2. OPEN FORUM-PUBLIC COMMENT AND RESPONSE

Provides an opportunity for the public to address the Commission on items which are not on the agenda. Public Comment will be limited to 15 minutes (if no one is in attendance for Public Comment, the regular meeting may begin), and it may not be used to make personal attacks, to air personality grievances, to make political endorsements or for political campaign purposes. Individuals should limit their comments to three minutes. Commissioners will not enter into a dialogue with citizens. Questions from the Commission will be for clarification only. Public Comment will not be used as a time for problem solving or reacting to the comments made, but rather for hearing the citizen for informational purposes only.

3. APPROVAL OF August 21, 2024 AGENDA

4. APPROVAL OF MINUTES FROM July 17, 2024 MEETING

5. ACTION ITEMS

6. GENERAL INFORMATION - PRESENTATIONS

- MISSISSIPPI GATEWAY REGIONAL PARK PROJECT UPDATE

7. OLD BUSINESS

8. WRITTEN REPORTS

- PROGRAM AND EVENTS UPDATE
- PARK PROJECTS UPDATE
- DIRECTORS REPORT

9. DISCUSSION ITEMS

- OPEN FORUM – QUESTION AND ANSWERS

10. VERBAL REPORTS AND ANNOUNCEMENTS

- CITY COUNCIL UPDATE – Councilmember McGarvey
- CITY HALL ENHANCEMENT TASK FORCE – Commissioners Erickson and Matthews
- COMMUNITY GOALS UPDATE TASK FORCE - Commissioner Parks
- KEY TOPICS FOR DISCUSSION AT THE NEXT RPAC MEETING
 - SEPTEMBER – BUDGET
 - OCTOBER - YOUTH SERVICES
- KEY DATES FOR FUTURE MEETINGS/EVENTS

11. ADJOURNMENT

Wednesday, July 17, 2024
Recreation & Parks Advisory Commission
Minutes

- 1. CALL TO ORDER/ROLL CALL - The Recreation & Parks Advisory Commission meeting was held at Community Activity Center and was called to order by Chairperson Erickson at 6:02 PM**

Commission Members present:

Dwain Erickson, Chairperson
Latrina Caldwell, At-large
Doug Crandall, At-large
Deborah Lande, Central
Taylor Murray, East
Terry Parks, At-large
Judy Purcell, Central
Kellina Quigley, At-large
Joshua Uloth, West

Absent:

Joe Gomez, Vice-Chair - Resigned 7/17/2024
Mercy Matthews, West
Miriam Osammor, East

Councilmember McGarvey

Aria Reickard, Youth Liaison
Klarissa Yu, Youth Liaison

Brooklyn Park Staff present:

Brad Tullberg, Director of Recreation and Parks
Greg Hoag, Parks and Buildings Maintenance Manager
Jeanine Machan, Administrative Assistant

- 2. OPEN FORUM-PUBLIC COMMENT AND RESPONSE**
N/A

3. APPROVAL OF AGENDA

**A Motion was made to amend the agenda to add Elections to 5.1 and move Deer Hunt to 5.2 by Commissioner Parks and second by Commissioner Uloth.
Motion unanimously approved.**

**A Motion was made to Approve the July 17, 2024 amended agenda by Commissioner Lande and second by Commissioner Purcell.
Motion unanimously approved.**

4. APPROVAL OF MINUTES

**A Motion was made to Approve the May 15, 2024 minutes by Commissioner Uloth and second by Commissioner Caldwell
Motion unanimously approved.**

5. ACTION ITEMS

5.1 ELECTIONS VICE CHAIRPERSON

**A Motion was made by Commissioner Lande to nominate Commissioner Purcell as Vice Chairperson. Second was made by Commissioner Caldwell.
No other nominations.
Motion unanimously approved.**

5.2 DEER HUNT ADDITIONAL LOCATION

Director Tullberg informed the Commission that the Izaak Walton League made a request to restore Zone 8 Banfill Island to the annual deer hunt. Director Tullberg provided a PowerPoint presentation providing background and to show the location (attached 4.0A).

Questions / Comments:

Commissioner Parks asked if Izaak Walton owned Banfill island? Director Tullberg replied they do not own the island, but they own the access to the island.

Commissioner Crandall asked if they were required to provide egress? Direct Tullberg stated they have in the past and this would also allow the hunters access through their property.

Commissioner Uloth is there a way to prevent the hunters from taking antler deer? Direct Tullberg stated the hunters go through an orientation and agree to rules they must follow, or they are banned from the hunt.

MOTION Vice Chair Purcell, SECOND Uloth, TO RECOMMEND TO CITY COUNCIL TO AUTHORIZE THE ADDITION OF THE BANFILL ISLAND LOCATION FOR AN ANTLERLESS DEER HUNT DURING THE 2024 ANNUAL DEER HUNT.

Motion unanimously approved.

6. GENERAL INFORMATION - PRESENTATIONS

6.1 PARK BOND PROJECT UPDATES

Director Tullberg provided a PowerPoint presentation on the progress of the 2018 Park Bond projects (see attached 4.0B). Project updates included Teen Center, CAC, Senior Center, Historic Eidem Farm, Trails, Wayfinding & Lighting and Natural Resources.

Questions/comments:

Commissioner Lande asked if there were currently two entrances into the parking lot at Zanewood?

Director Tullberg stated there is only one. Lande asked if staff considered two with the new facility?

Director Tullberg said two entrances were considered, however, Hennepin County would not approve due to the minimum distance between access points was not met.

Commissioner Lande asked if staff have considered bringing in partners such as Three Rivers or the Arboretum for assistance with landscaping and programming? Director Tullberg stated that staff have looked at these partnerships.

Commissioner Lande asked for more details on the kitchen space in the new Teen Center? Director Tullberg stated that the space is set up for mainly a concessions kitchen.

Vice Chair Purcell asked about for clarification on the Fusion and Flex space? Director Tullberg confirmed that both spaces are 745 sq. ft.

Commissioner Lande asked that CDBG is explained? Director Tullberg stated that CDBG stands for Community Development Block Grants are Federal funding that is distributed through Hennepin County to the City of Brooklyn Park. The city receives approximately \$450M / year.

Commissioner Uloth ask if Hennepin County offers other grant opportunities besides sports for Zanewood? Director Tullberg stated there are multiple different grant opportunities for program funding that staff review and apply for such as the Arts / Beautification Grant. There is not much for bricks and mortar. That is where the pursuit of the Peter J King Foundation that specifically funds building is being sought.

Commissioner Lande asked when staff would be bringing the Zanewood Project back to city council? Director Tullberg stated staff are planning on September 9th for final approval. Staff is optimistic that breaking ground will happen in October.

Commissioner Uloth asked if there where many contractors interested in this project? Director Tullberg stated that staff is expecting several companies to be part of the bid process.

Commissioner Parks stated that he is not a fan of reallocating funds from the 2018 Park Bond Referendum that was voted on. Director Tullberg stated that he is committed to all the things that were promised to the community will still happen.

Vice Chair Purcell asked where the activity / bathroom building at Eidem Historic Farm be located? Director Tullberg stated it would be to the east side of the parking lot, east of the farmhouse.

Commissioner Uloth asked what is phased 3 of the wayfinding, trails and lighting? Director Tullberg stated that phase 3 is the monument signage, such as "welcome to Brooklyn Park".

Commissioner Murray asked that the \$2M for the CAC will need to be revised? Director Tullberg stated that the scope of what the CAC improvements will be is still up in the air. Until it is more finalized the final number is unknown.

7. OLD BUSINESS

7.1 7.2 RFCA 1st and 2nd Reading of Proposed Park Cannabis Use Ordinance – Passed

7.2 3B.3 Proclamation of Parks and Recreation Month

7.3 7.1 Teen Center Project Funding Plan

8. WRITTEN REPORTS

1. PROGRAM AND EVENTS UPDATE
2. PARK PROJECTS UPDATE
3. DIRECTORS REPORT

Manager Hoag mentioned an addition that was not in the report. Rehabilitation of the parking lots at Central Park as well as Dog Park parking lot at Brookdale Park.

Director Tullberg informed RPAC about the large gatherings that staff in Recreation and Parks and the Police Department are working together to disperse and get in front of the gatherings if possible. He stated that recreation and parks and police staff from surrounding areas are meeting on July 29 in New Brighton to discuss how to work together.

9. DISCUSSION ITEMS

Chairperson Erickson ask for an update on amplified sound. Director Tullberg stated that staff is still working through complaints.

10. VERBAL REPORTS AND ANNOUNCEMENTS

1. CITY COUNCIL UPDATE – Councilmember McGarvey
No Report

2. CITY HALL ENHANCEMENT TASK FORCE Commissioners Erickson and Matthews
Chairperson Erickson stated the June meeting was cancelled. No Report.

3. COMMUNITY GOALS STEERING COMMITTEE UPDATE - Commissioner Parks
Commissioner Parks stated the June meeting was cancelled. Community engagement dates are set for August 15, 20 and 27.

4. KEY TOPICS FOR DISCUSSION AT THE NEXT RPAC MEETING

- AUGUST – MEET AT MISSISSIPPI GATEWAY REGIONAL PARK
- SEPTEMBER – BUDGET

5. KEY DATES FOR FUTURE MEETINGS/EVENTS

- AUGUST 5TH - JOINT CITY COUNCIL / COMMISSIONERS WORK SESSION

11. ADJOURNMENT

A Motion was made by Commissioner Uloth to close the meeting, second by Commissioner Murray. Motion unanimously approved.

Adjourned by Chairperson Erickson at 7:57 PM

Submitted respectfully,
Jeanine Machan
Secretary

Attachments:

- 4.0A 2024 Deer Management - Add Location**
- 4.0B 2018 Park Bond Project Update 7.17.24**

Annual Deer Management Plan

Recreation & Parks Advisory Commission

July 17, 2024

Brad Tullberg, Recreation & Parks Director

DEER MANAGEMENT HISTORY

- In 2011, City Council approved Deer Management Plan
 - Identifies the number of deer that the natural habitat can support within city
 - The plan recommends 15 to 20 deer per square mile
 - 45 to 60 deer in the northern portion of the city
 - 15 to 20 deer along the Mississippi River south of Highway 610
 - 15 to 20 in the Palmer Lake Nature Area
- City works in partnership with Three Rivers Parks District and seven other Hennepin County municipal partners to:
 1. Conduct the annual fly over to determine herd count and the targeted number of deer to remove from herd in the next year.
 2. Historically, we have contracted with Metro Bowhunters Resource Base (MBRB) to conduct controlled deer hunt.

DEER MANAGEMENT HISTORY

- Initially able to hunt 11 different zones, now just four zones in 2024
 - ZONE 1 **NORTHWOODS PARK**
 - ZONE 2 RUSH CREEK TRAIL 102nd & REGENT (Dropped)
 - ZONE 3 ENVIRONMENTAL PARK (Construction @ MGRP)
 - ZONE 4 COON RAPIDS DAM (Construction @ MGRP)
 - ZONE 5 **PALMER LAKE PARK**
 - ZONE 6 WOODS AT 103rd & WINNETKA (Developed)
 - ZONE 7 RUSH CREEK TRAIL 101st & 169 (Developed)
 - **ZONE 8 BANFILL ISLAND (dropped 2022 – Izaak Walton League)**
 - ZONE 9 JEWELL PARK (Dropped too close to homes)
 - ZONE 10 **GREENHAVEN PARK**
 - ZONE 11 **BROOKDALE PARK**

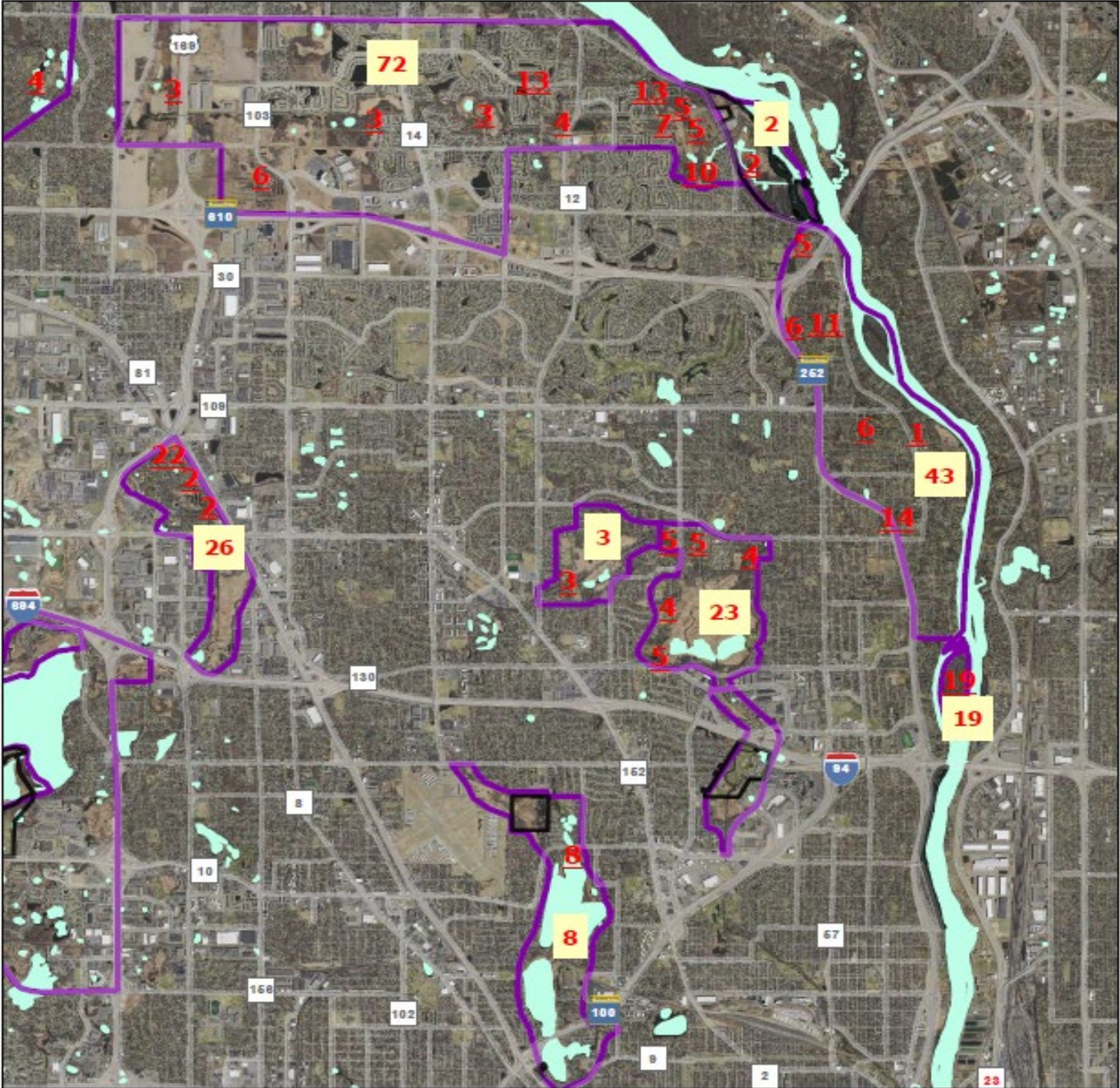

AERIAL SURVEY YEAR	AERIAL DEER COUNT
2019	171
2020	172
2021	No count
2022	114
2023	196
2024	No count

City of Brooklyn Park Brooklyn Center
 1/12/2023 - Aerial Deer Survey
 Total Deer Counted - 196



PROPOSED 2024 DEER HUNT DATES

2024 Hunt Dates:

- October 7 & 8, October 9th
- October 28 & 29, October 30th
- November 11 & 12, November 13th

Proposed change back to three hunt days instead of two hunt days and makeup day.

REQUESTED ACTION

Recommend the Following to City Council:

TO AUTHORIZE THE ADDITION OF THE BANFILL ISLAND LOCATION FOR AN ANTLERLESS DEER HUNT DURING THE 2024 ANNUAL DEER HUNT.

QUESTIONS?

Brad Tullberg

Director of Recreation and Parks

763-493-8344

Brad.Tullberg@brooklynpark.org

**Brooklyn
Park**



Unique.
United.

Undiscovered.

**City of Brooklyn Park
Recreation & Parks Department**

5600 85th Ave. N.
Brooklyn Park, MN 55443
763-493-8333

www.brooklynpark.org

Facebook: [/brooklynparkmn](https://www.facebook.com/brooklynparkmn)

Twitter: [@brooklynpark](https://twitter.com/brooklynpark)

YouTube: [/user/brooklynparkmncity](https://www.youtube.com/user/brooklynparkmncity)

Park Bond Project Update

Recreation and Parks Advisory Commission

Brad Tullberg, Recreation and Parks Director

July 17, 2024



TEEN CENTER PROJECT

Project Goals

Staff worked with Design by Melo to develop plans for a facility that would meet three primary goals:

- A safe space where young people can gather and be themselves
- A place to develop job skills and help connect them with jobs
- A place to be creative and dream about the future



ART GARDEN

This architectural rendering shows a school campus with a central building and several outdoor areas. The Art Garden is a green space with a path leading to the building. The Basketball Court is a paved area with a grid pattern. The Playground is a large green area with a winding path and trees. The Park Entry is a paved area with trees and a path leading to the building. The building has a modern design with large windows and a flat roof. The campus is surrounded by a road and a sidewalk.

BASKETBALL COURT

PARK ENTRY

PLAYGROUND



THE WOOD



1st Floor

16,147 sq.ft.

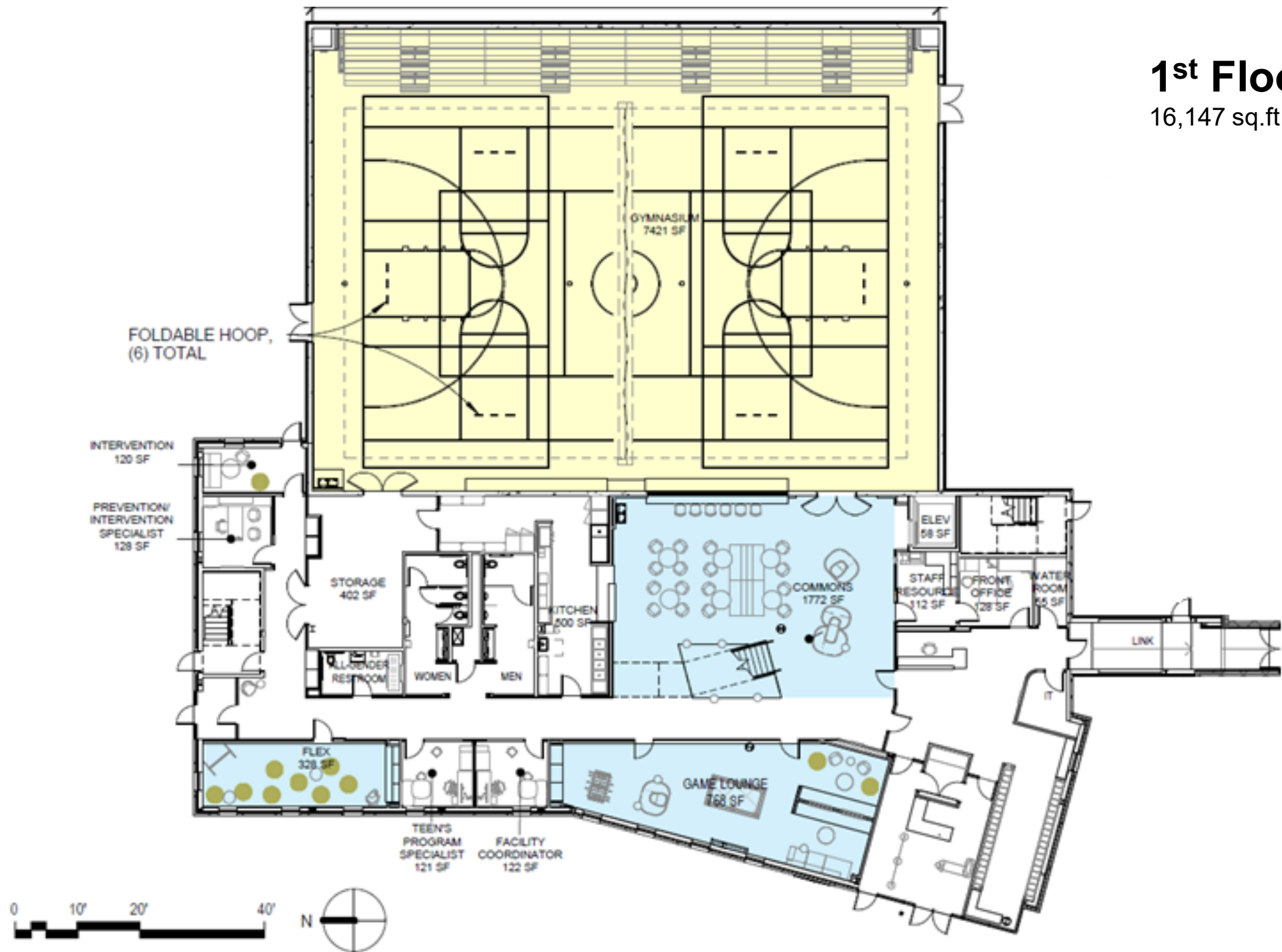

2nd Floor

8,481 sq.ft.

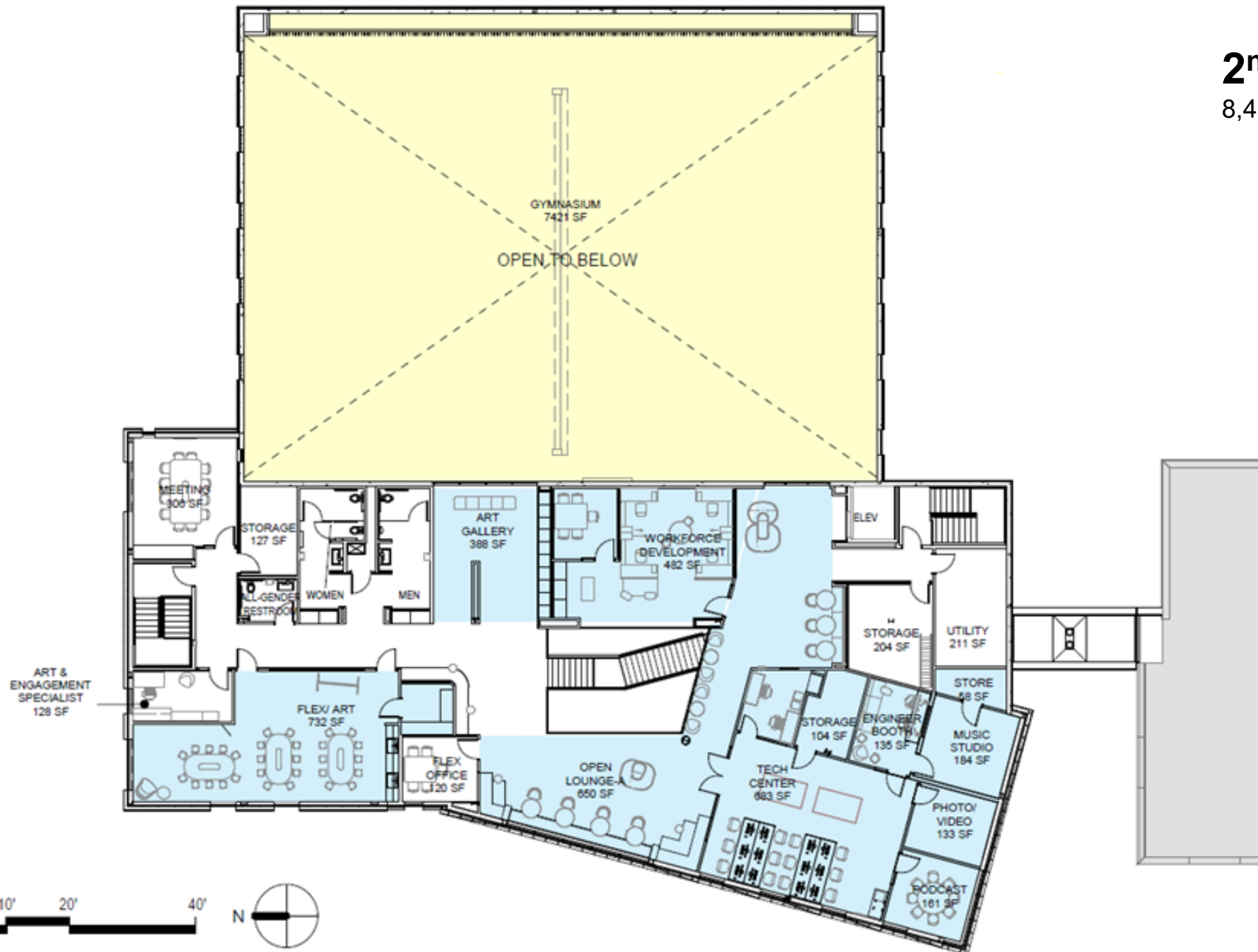

RENOVATED EXISTING FACILITY

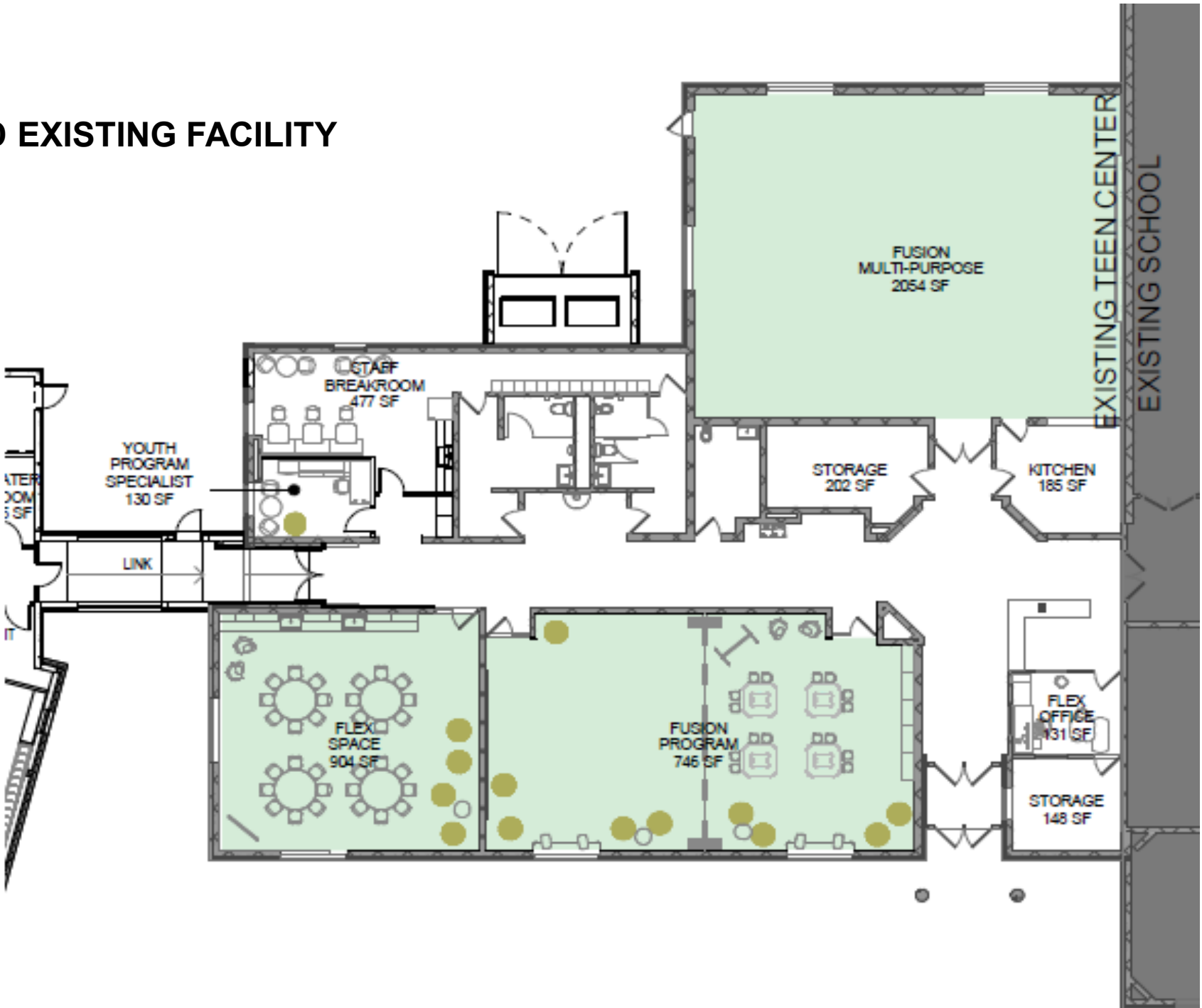



Commons Area

2nd Floor Commons Area



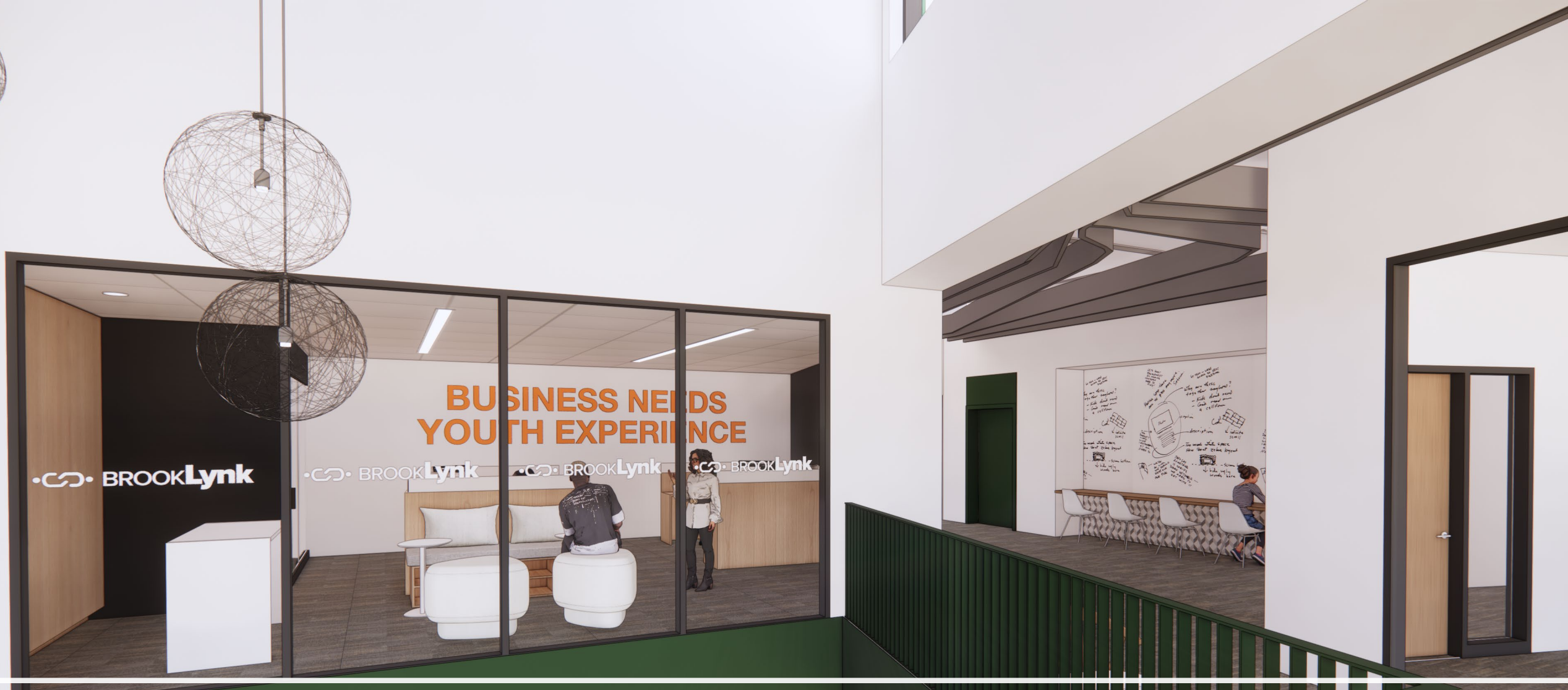

2nd Floor Commons Area

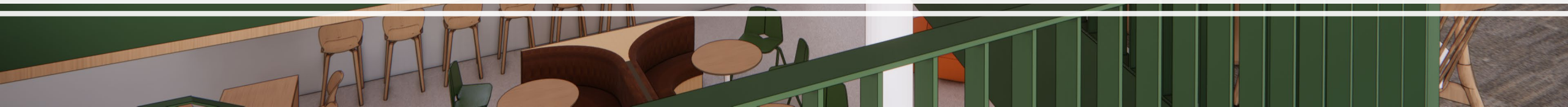

Current Funding

- Total Estimated Project Cost is \$10M
- During planning process, staff planned to secure \$4M in State Bonding, \$4M Congressionally Directed Spending, \$2M from 2018 Park Bond
- Currently secured to date:
 - \$2M from 2018 Park Bond Referendum
 - \$500k from 2023 Federal Community Project Funding
 - \$150k from Best Buy Teen Tech Center Grant

Additional Funding Possibilities

Staff have identified the following additional strategies to fully fund the project:

- \$750k from CDBG funding over next three funding cycles (\$250k per year)
- \$1.5M from the Open Space, Land Acquisition and Development (OSLAD) fund
- \$5.1M reallocation from the 2018 Park Bond Referendum

Park Bond Reallocation Recommendation

\$3.5M from the future park to support large picnicking at end of BLRT (101st and Winnetka)

- Create a park with 300-person picnic area and would allow amplified sound
- In 2018, BLRT was expected to be constructed by now (more likely 2030)
- Existing plan shows Met Council purchasing 11 acres of existing park land for Operations and Maintenance Facility east of Xylon Avenue (\$4M)
- Shift \$3.5M from the 2018 Park Bond to Teen Center and utilize funds from the sale of land to Met Council to construct the park at end of BLRT

Park Bond Reallocation Recommendation

\$400k from Natural Resources

- Utilize annual CIP funding to maintain Natural Resource Areas
- Reduces total project budget to \$100,000

\$800k from Historic Eidem Farm

- Leverage DNR Outdoor Grant to construct picnic shelter & bathrooms
- Reduces total project budget to \$600,000

\$400k from Trails, Wayfinding and Lighting

- Leverage future grants to continue trail connections
- Reduces total project budget to \$2,000,000

Future Grant Opportunities

Staff would continue to pursue additional grant opportunities to fund construction

- Hennepin Youth Sports – Facility Grant
- US Bank Our Courts, Our Future
- Peter J. King Foundation

Other Funding Options

- Consider including Teen Center in a referendum for large city projects
- Delay the Teen Center project and pursue 2025 MN State Bonding

Project Timeline

- May 2023 – Community Engagement Kickoff
- September 2023 – Design Development Process begins
- March 2024 – Development of Construction Documents begins
- July 2024 – Advertise for bids
- August 2024 – Award project
- September 2024 – Begin Construction
- May 2025 – Construction complete



**COMMUNITY ACTIVITY
CENTER
IMPROVEMENTS**

Project Update

- Request to change language from 2023 bonding was approved
- Request for additional \$12M – no 2024 Bonding Bill
- Other factors (Teen Center, Central Fire)
- Timing
 - March 7, 2024 – Community Engagement Meeting
 - June 3, 2024 – Discussion with City Council
 - August 26, 2024 – Request approval to begin planning process
- Planning timeline is about 9 months
- Likely seeking 2025 State Bonding



SENIOR CENTER

Project Update

- Waiting on Central Fire Station decision
- Planning to renovate the former Central Fire Station
- Estimated Timeline
 - June 2025 - Central Fire Construction begins
 - October 2025 – Senior Center renovation planning begins
 - October 2026 – Fire moves into new station/ Senior Center Construction begins
 - January 2027 – Senior Center opens



HISTORIC EIDEM FARM

Project Update

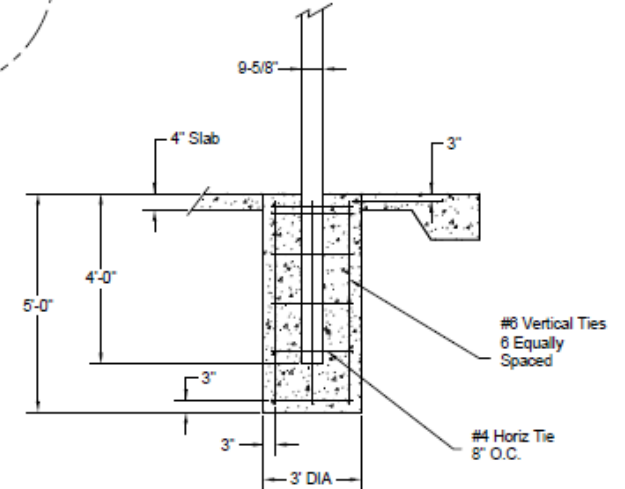
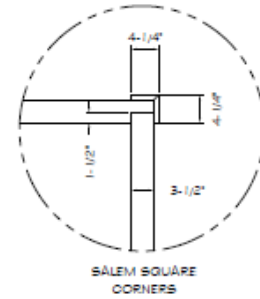
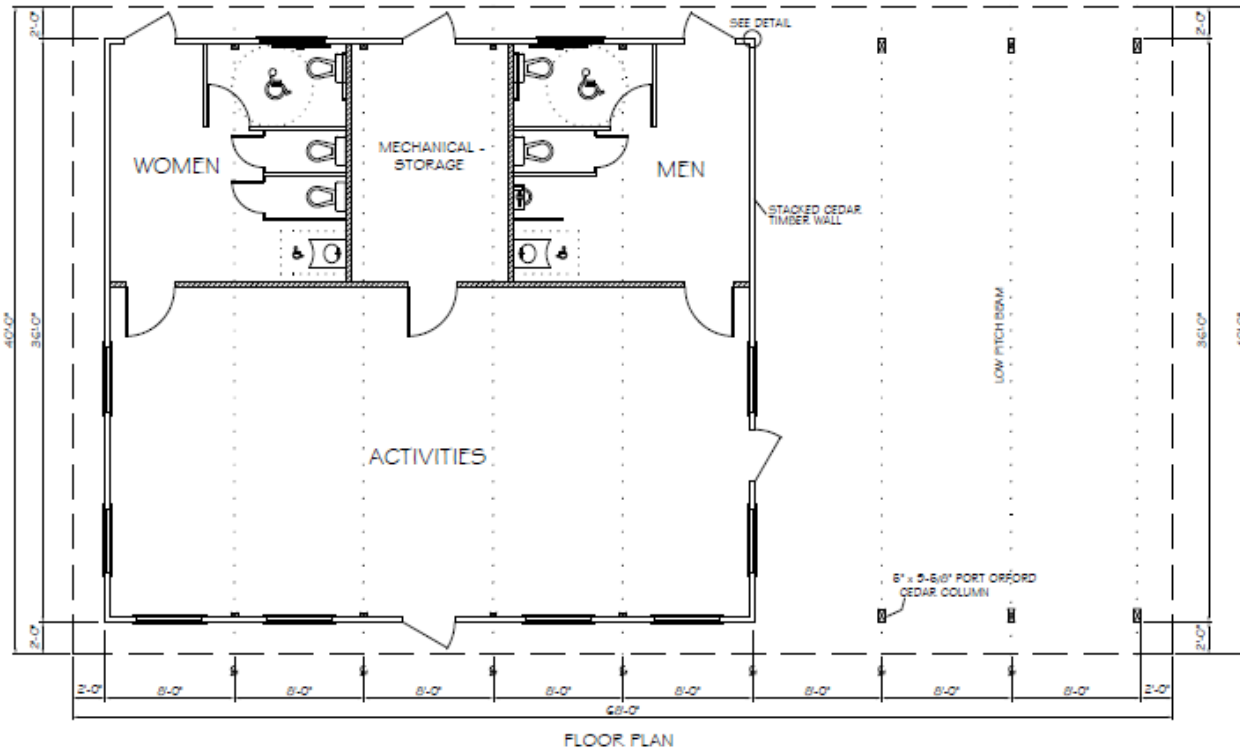
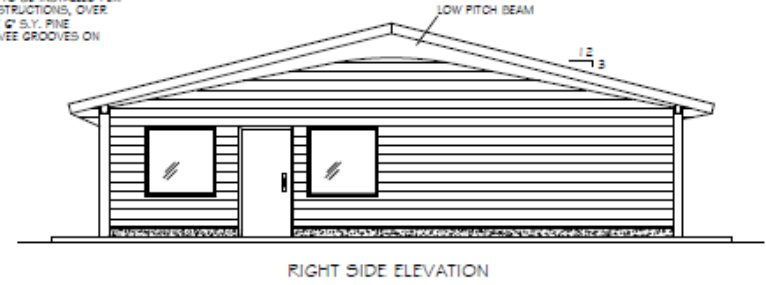
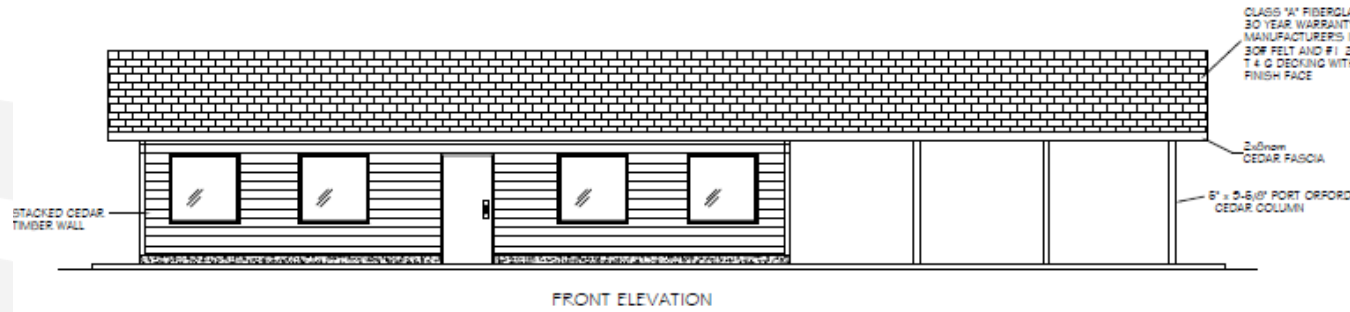

Column/Footing Detail
Final Size TBD
Concrete Pier By Others





TRAILS, WAYFINDING & LIGHTING

Project Update

- Wayfinding Phase 1 & 2 installation have started
- Phase 3 on hold until other phases have been implemented

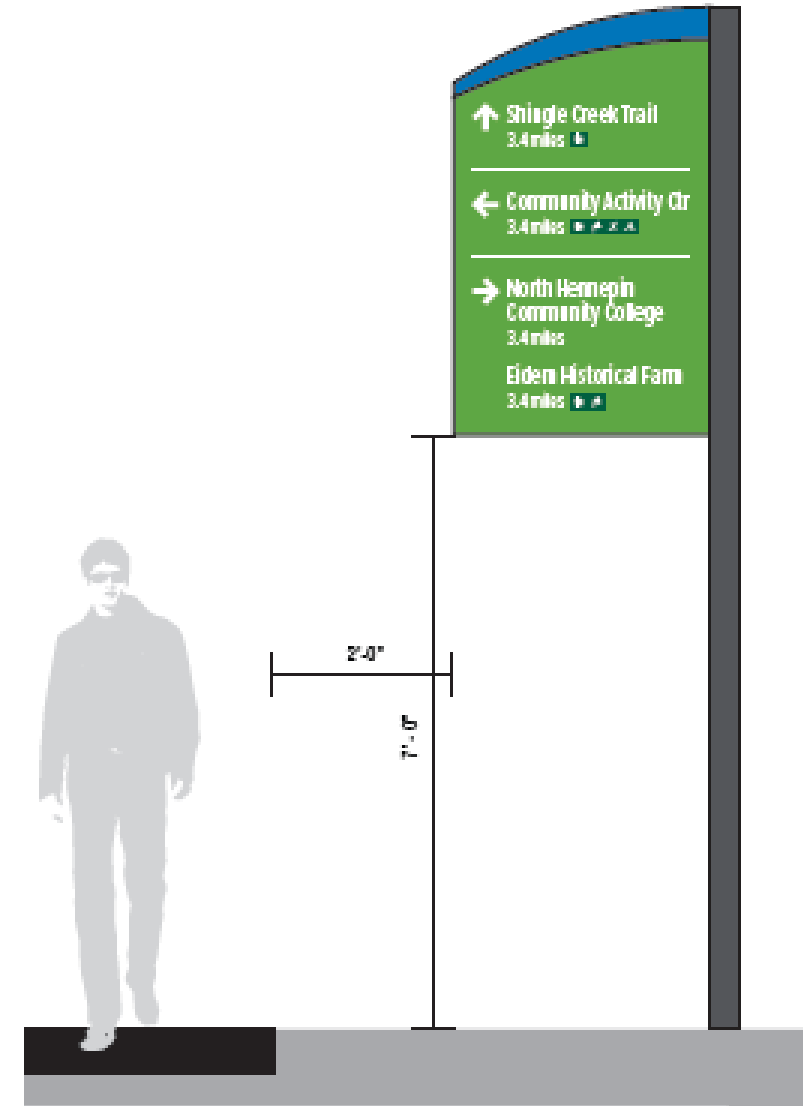



NATURAL RESOURCES

Project Update

- Focus Areas
 - River Park (northern prairie)
 - Village Creek
 - CAC Pond
 - Edinbrook Channel
- Using CIP funding
- Work is on-going and not as much project based
- Do not have staffing to create more natural resource areas to manage

2018 Park Bond Referendum

● Natural Resources	\$ 500,000
● Trails, Lighting & Wayfinding	\$ 2,400,000
● Park Reinvestment	\$13,100,000
● Lakeland, Hartkopf & Norwood Park (\$5.2M) *	
● Kitchens at Central and River Park shelter (\$400k) *	
● Renovate Willowstone, Northwoods & Monroe buildings (\$1.5M) *	
● Construct Large Picnic Area @ 101 st & Winnetka (\$3.5M)	
● Other Park Improvements (\$2.5M)	
● Teen Center	\$ 2,000,000
● Community Activity Center & Senior Center	\$ 4,000,000
● Fields and Courts (Noble baseball field & turf fields) *	\$ 2,600,000
● Historic Eidem Farm	\$ 1,400,000

2018 Park Bond Referendum

<u>PARK BOND PROJECT</u>	<u>ORIGINAL BUDGET</u>	<u>SPENT TO DATE</u>	<u>REVISED BUDGET</u>	<u>REMAINING BALANCE</u>
Natural Resources	\$ 500,000	\$ 2,264	\$ 100,000	\$ 97,736
Trails, Wayfinding & Lighting	\$ 2,400,000	\$ 249,069	\$ 2,000,000	\$ 1,750,931
Historic Eidem Farm	\$ 1,400,000	\$ 157,056	\$ 600,000	\$ 442,944
Teen Center	\$ 2,000,000	\$ 0	\$ 7,100,000	\$ 7,100,000
Fields & Courts	\$ 2,600,000	\$ 5,019,914	\$ 5,019,914	\$ 0
Park Reinvestment	\$ 13,100,000	\$ 6,619,255	\$ 7,180,086	\$ 560,831
CAC Improvements	\$ 2,000,000	\$ -	\$ 2,000,000	\$ 2,000,000
Senior Center	\$ 2,000,000	\$ -	\$ 2,000,000	\$ 2,000,000
	\$ 26,000,000	\$ 12,047,558	\$ 26,000,000	\$ 13,952,442

City of Brooklyn Park RECREATION AND PARKS ADVISORY COMMISSION			
Agenda Item	6.1	Meeting Date:	August 21, 2024
Agenda Section:	General Information - Presentations	Presented By:	Brad Tullberg, Director of Recreation & Parks Matt Swenson, Three Rivers Park District
Recreation & Parks Director Proposed Action	Mississippi Gateway Regional Park Update		

Overview:

Since 2015, City staff have been working in partnership with the Three Rivers Park District (TRPD) to engage the community and agency stakeholders in development of the vision and Joint Master Plan for the Mississippi Gateway Regional Park (formerly Coon Rapids Dam Regional Park) and Environmental Nature Area. The city owns the Environmental Nature Area along the west side of West River Road, while TRPD owns the parkland on the east side.

The vision for the Mississippi Gateway Regional Park is to be “a gateway for everyone to connect with the Mississippi River and its dynamic environment.” The Mississippi Gateway Regional Park Master Plan includes a new Mississippi Gateway Center, Treetop Trail, nature play areas, Mini-Mississippi Play and Education Feature, field learning labs, South Pond Learning Lab, nature interpretation nodes, and improved trails, fishing platform, picnicking, non-motorized boat launch, archery range, off-leash dog area, natural areas and more. These amenities support the goals that Brooklyn Park community members have identified as priorities through the Park System Plan community engagement effort— specifically, priorities for providing connections to nature, the Mississippi River, and opportunities for year-round outdoor recreation.

On January 22, 2018, the City Council approved the Joint Master Plan for Mississippi Gateway Regional Park/Environmental Nature Area. In December 2020, the City Council authorized staff to enter into a cooperative agreement for both portions of the park to be designed, constructed, and operate as one cohesive park. Under the cooperative agreement, one of the prerequisites to beginning construction is the approval of the project budget by the Brooklyn Park City Council. The estimated budget was \$4.5M for the design development and construction for the west unit of the park. TRPD is responsible for the cost of the east unit of the park in addition to the Maintenance Building and Rush Creek Regional Trail located on the western portion.

At the August Recreation and Parks Advisory Commission meeting, Matt Swenson from Three Rivers Park District will give a project update.

Primary Issues/Alternatives to Consider:

Budgetary/Fiscal Issues:

Attachments:

City of Brooklyn Park RECREATION AND PARKS ADVISORY COMMISSION			
Agenda Item	7.0	Meeting Date:	August 21, 2024
Agenda Section:	Old Business	Presented By:	Brad Tullberg, Director of Recreation and Parks
Recreation & Parks Director Proposed Action	Past City Council Agenda Items and Community Engagement		

Overview:

The following attachments were presented at City Council Meetings or Community Engagement Sessions held since our last RPAC meeting.

7.1 4.6 DEER HUNT ADDITION CC 7/22/2024

Primary Issues/Alternatives to Consider:

NA

Budgetary/Fiscal Issues:

NA

Attachments:

7.1 4.6 RFCA DEER HUNT REPORT

City of Brooklyn Park Request for Council Action

Agenda Item:	4.6	Meeting Date:	July 22, 2024
Agenda Section:	Consent	Originating Department:	Recreation and Parks
Resolution:	X	Prepared By:	Brad Tullberg, Director of Recreation and Parks
Ordinance:	N/A		
Attachments:	4	Presented By:	Brad Tullberg
Item:	Authorize Additional Location for 2024 Deer Hunt		

City Manager's Proposed Action:

MOTION _____, SECOND _____, TO WAIVE THE READING AND ADOPT RESOLUTION #2024-____ TO AUTHORIZE THE ADDITION OF THE BANFILL ISLAND LOCATION FOR AN ANTLERLESS DEER HUNT DURING THE 2024 ANNUAL DEER HUNT.

Overview:

The Deer Management Plan identifies the numbers of deer within a range that the natural habitat can support in Brooklyn Park. The plan recommends 15 to 20 deer per square mile which translates to 45 to 60 deer in the northern portion of the city, 15 to 20 deer along the Mississippi River south of Highway 610, and 15 to 20 in the Palmer Lake Nature Area. Since 2011, the City Council has supported a Deer Management Program consisting of a controlled archery deer hunt. Each fall, the city utilizes the Metro Bowhunters Resource Base (MBRB) to conduct the controlled archery deer hunt. The MBRB manages the hunter's application process.

The City Council approved the following deer hunt dates and locations at its May 13 meeting:

2024 Hunt Dates:

October 7 & 8, October 9
October 28 & 29, October 30
November 11 & 12, November 13

Hunt locations include Northwoods Park, Palmer Lake, Greenhaven Park, and Brookdale Park Open Space.

The Banfill Island was removed from the Deer Hunt in 2022 at the request of the Izaak Walton League and was not offered as a hunt location in 2023. After the 2024 deer hunt was approved, staff were approached by the Izaak Walton League Board of Directors requesting to restore the Banfill Island hunt as an antlerless deer only hunt.

Primary Issues/Alternatives to Consider:

Staff are recommending that Banfill Island be added as a controlled archery deer hunt for antlerless deer only on the dates of the 2024 deer hunt.

Budgetary/Fiscal Issues:

There would be no additional cost to add the Banfill Island location to the 2024 Deer Hunt

Attachments:

- 4.6A RESOLUTION
- 4.6B 2023 ANNUAL DEER SURVEY
- 4.6C ZONE 8 – IZAAK WALTON LEAGUE – BANFILL ISLAND
- 4.6D IZAAK WALTON LEAGUE LETTER OF REQUEST

City of Brooklyn Park Recreation and Parks Advisory Commission			
Agenda Item:	8.1	Meeting Date:	August 21, 2024
Agenda Section:	Written Reports	Presented By:	Pam McBride, Youth Services Manager; Jen Gillard, Recreation Manager
Recreation & Parks Director Proposed Action	Program and Events Update		

August 2024

- 2 Brooklyn Park Night Out at Central Park
- 3 Sounds of Asia at River Park
- 8 Brooklyn Community Band Family Concert at the Historic Eidem Farm
- 12 Bonus Week for Summer Camp Begins
- 17 Back 2 School BBQ at Zanewood Recreation Center
- 23 Happy Hour, Music and Movie at the Historic Eidem Farm
- 29 Family Farm Activities and Movie at the Historic Eidem Farm

September 2024

- 5 Brooklyn Park Dance Open House at the CAC
- 7 Pick Up Truck Opera: Faust at North Hennepin Community College
- 13 Happy Hour & Concert at the Farm
- 14 Salsa del Soul at Community Activity Center Lawn
- 16 Brooklyn Park Dance classes begin
- 21 September Soul Arts & Music Festival at Zanewood Recreation Center

Farm Open Gate Hours Mon & Wed 10 am – 4 pm | Tues & Thurs 10 am – 7 pm | Sat 10 am – 3 pm
 Wednesday weekly Farmers Market July 10 – October 9, 1 – 6 pm
 Weekly drop-in activities for adults 50+ at the CAC Monday-Friday
 Wednesday weekly Tech Support for Seniors at the CAC
 Weekly Fitness classes at the CAC Mon/Tues/Wed/Fri
 Weekly drop-in activities for youth and teens at Zanewood Recreation Center Monday-Friday 2-8pm

Program and Event Updates:

Brooklyn Park Youth Outreach Team and Intervention Services

The Brooklyn Park Youth Outreach Team works M-F from 5:00-9:00 pm each day in the community connecting young people to resources, redirecting negative energy, sharing positive activities, and working in partnership with police to maintain a safe and healthy community.

Intervention Team is increasing access of Intervention Services with a form that is accessible through a QR code to providers and people supporting young people. This form is used to connect and provide essential services.



Young Women’s group- ages, 14-17 years old, Every Friday 4:00- 6:00pm at Zanewood
Young Men’s group- ages 16- 18-year-old, every Monday, 4:30- 6:30pm at Zanewood

Adult Fitness

Summer sessions of adult fitness classes are in full swing at the Community Activity Center including regularly scheduled Monday, Tuesday, Wednesday & Friday morning fitness classes, Tuesday evening yoga, and Wednesday evening AfroBeats Dance Workout class. The fall fitness schedule is now finalized – program offerings are staying the same however we have a transition of a new Hatha Yoga instructor while our seasoned instructor, Julie Thour phases out for retirement.

Adults on the Move

The July - September Adults on the Move Guide is available at www.brooklynpark.org/adults The guide features luncheons, trips, lifelong learning opportunities, community programs, fitness classes, resources, and weekly activities. The guide is available online and mailed to about 675 people.

Day Trips

August 6 a full bus of 54 people departed Brooklyn Park for a full daytrip to Duluth. The day included scenic stops, a drive along Skyline Drive, a narrated boat tour featuring sites from Lake Superior and the interior harbor, lunch at the Pickwick, and a stop at Tobies on the way home. The September 18 trip is a City History tour in Rochester. On October 15 a full bus will head to Warrens Wisconsin for a Cranberry Country tour.

Outreach

Recreation & Parks and the Fire staff are planning a few outreach programs at senior living sites in September around Falls Prevention Awareness Month and BP Future Goals Engagement.

Weekly Adult Social Groups

Weekly social activity groups are actively using their 2024 yearly membership. Participants are enrolled in one or more weekly activities. Members have access to 14 activity groups per week. Social activity groups include: several art/craft groups, cribbage, bingo, poker, Mah Jongh, 65 Rummy, 500 Cards, Dominoes, Scrabble, and a Book Club.

Events

Brooklyn Park Farmers Market season starts on July 10 and runs every Wednesday until October 9 from 1-6pm at North Hennepin Community College parking lot. This year, there are a total of 22 vendors selling a range of produce, baked goods, and other craft items.

Summer Splash took place on July 12 from 5 – 7 p.m. at Zanewood Recreation Center. The event featured inflatables, water games, and DJ Snuggles along with community resources. About 400 people attended.

Jazz in July took place on July 19 at the Community Activity Center from 5 – 9 p.m. This event featured three jazz groups, a happy hour hosted by Lion's Club and community resources. About 200 people attended.

Brooklyn Park Night Out took place on Friday, August 2 at Central Park from 7 p.m. – 11 p.m. and featured Fire, PD, DJ dance party, and a movie at dusk. The day was especially hot. About 250 people attended, half our usual turnout.

Sounds of Asia took place on Saturday, August 3 at River Park from 11 a.m. – 2 p.m. and featured music and performances from local Asian artists under the shade of the trees. About 150 people attended.

Back to School BBQ will take place on Saturday, August 17 at Zanewood Recreation Center from 11 a.m. – 3 p.m. and features free food, a backpack give-away, and DJ Snuggles. Starting in July, we begin collecting school supplies for this event. Drop off at City Hall or the Community Activity Center front desk.

In partnership with the Historic Eidem Farm, the events team is co-hosting two Movies on the Barn events. The first one is on Friday, August 23, featuring happy hour, music from Jake Stow, followed by a showing of the Wedding Singer. Doors open at 6:00pm and the movie starts at dusk. The second movie is on Thursday, August 29 and is geared towards families with activities and a showing of the movie Babe. Doors open at 6pm and the movie starts at dusk.

The Wedding Singer will show on August 23 at dusk. The event will take place at Historic Eidem Farm and will be preceded by a happy hour and live music.

The movie Babe will show on August 29 at dusk. The event will take place at Historic Eidem Farm and will be preceded by family friendly farm activities.

Pick Up Truck Opera: Faust at North Hennepin Community College will take place on September 7 from 2 p.m. – 3:30 p.m. The event features Mixed Precipitations annual outdoor opera.

Salsa del Soul at Community Activity Center Lawn will take place on September 14 from 11 a.m. – 12:30 p.m. This 7-piece band features music from South America and the Caribbean.

September Soul Arts & Music Festival at Zanewood Recreation Center will take place on September 21 from 4 – 7 p.m. This event will feature music and art vendors.

See attached flyer for 2024 summer event schedule.

Aquatics

Summer 2024 aquatics programs wrapped up on Thursday, August 8th. Programs included early morning swim teams that run from 7:45-8:45AM for middle-school & high school students, followed by morning swim lessons offered from 9AM-1:30PM. Afternoons at the pool consist of \$4 open-swim opportunities to the community which are supervised by Brooklyn Park Lifeguards. Evening swim lessons were held each day from 4PM-9PM. Lessons run on a Monday-Thursday schedule. Swim offerings included regular group classes including preschool lessons, levels 1-6, aqua-teen intro classes, adult classes, our Women & Girls only swim class, adaptive aquatics classes, and several opportunities for private/paired/family style small group lessons.

Overall, the BP Aquatics team welcomed 320 families, and 681 total participants throughout our summer program this year! With morning-mid-day-afternoon-evening programming, the team is thrilled to end-out another successful summer.

Fall aquatics planning is underway as staff prepare for the September-December 2024 registration day that will open on Tuesday, August 20th at 10A.M.

Adaptive Recreation/ Inclusion Services:

Summer adaptive recreation programs will wrap up on Friday, August 23. Adaptive Recreation programs included two Adaptive Aquatics classes, Adaptive Fitness, Beauty Within: Adaptive Art, the Adaptive Rec Fridays series run in partnership with Courage Kenny Sport and Recreation Department, partnership Reach for Resources programs, and adaptive recreation programs implemented by our Therapeutic Recreation Interns. Inclusion Services was busy this summer with a team of 12 Inclusion Specialists and two Therapeutic Recreation Interns supporting youth sports, K5 fusion, summer camp, aquatics, ice skating, and more.

Our Therapeutic Recreation Interns will be completing their 15-week, 600-hour internship experience with us on Friday, August 23 and Friday, September 6.

Youth Sports

Youth Summer Sports is wrapping up for the summer season very soon. It has been a successful summer with full and mostly full classes. Lil' Tykes and Tiny tots have been running sampler sports with young ones and parents all summer. Youth soccer, tee ball, and sampler have been popular as well. Instructor Mia and Instructor Moyin have brought good energy to the classes and parents are saying good things. They were joined by a Brooklynk intern named Kenyu and he was assisting in the class and encouraging our young ones.

Tobler Gymnastics was back for another summer and the program had increased numbers possibly due to the summer Olympics.

Park Center Basketball Camp and BP Rec and Parks collaboration was on its fourth year and was run by Coach James Ware and his staff. There were four, one-week camps that were offered all together. Coach Ware and his staff and students did a wonderful job with the campers.

First year collaboration with Sanneh Foundation summer camps took place in Brooklyn Park this year and was very successful. Sanneh instructors and student teachers were able to run 3 very full summer sports camps. Those camps included the sport of soccer, basketball, and pickleball. All classes were full with basketball and pickleball having huge wait lists with high demand. Parents were excited to see the program in their city and loved the proximity to home. Great job Sanneh and Company! We hope to partner with them next year!

Would like to give a shout out to the adaptive recreation department and its staff in helping many students in our program with their inclusion needs. They did not miss a beat or miss anyone who needed the help. It is great to see them in the space helping support young ones in sports and recreation. What a gem of a group. This was my first year working with Brooklyn Park and seeing this service in person brings good joy and good pride in the service that we offer.

Adult Sports

Adult Softball players were kept busy this summer with Thursday Softball. The softball fields at Noble Park continue to be wonderfully prepped and beautiful for our players. We introduced a new scheduling software called Team Sideline, and the players and captains were able to navigate through standings and schedules with ease. 15 total teams embarked on the softball fields every week with high recreational enthusiasm. Team KSP were the league champions with Team Life Rides winning the tournament play. Fall season begins on August 22! Registration is almost full.

Historic Eidem Farm

Farm summer camps have wrapped up on Thursday, August 15. Session 1 & 2 of Critter Camp were completely full with 48 participants and ran from June 17-27, 9-11:30am. Campers spent the morning rotating through daily activity stations with their group including song circle, craft, story time, games, snack, and farm exploration. Session 1 of Nature Preschool ran from July 8-July 25 with 36 participants. Session 2 of Nature Preschool ran from July 29-August 15 with 30 participants. Daily activities include circle time, creative arts, story time, games, snacks, and nature exploration.

Open Gate Hours began on May 20 where the Farm is open for free exploration, storytime, and drop-in activities:

- Monday, Wednesday 10am-4pm
- Tuesday, Thursday, 10am-7pm
- Saturday 10am-3pm

Over 2,000 people have attended Open Gate in June and July. Every Tuesday Storytime takes place on the side porch of the farmhouse with a planned activity to follow. The Family Fun concert series wrapped up with a performance from the Community Band performance on Thursday, August 8, over 100 people attended their performance.

Two Happy Hours are planned at the Farm for August 23 and September 13 in partnership with Heavy Rotation Brewery. The August 13 Happy Hour will from 6-10pm and will feature music from Jake Stow and with a showing of the Wedding singer to follow at dusk. The September 13 Happy Hour will be from 5-9:30pm and will feature a performance by Pirates Guitars and Beach Front Bars, games, and food from La Cocina food truck.

A Movie on the Barn is planned for August 29 at dusk featuring the movie Babe. Farm crafts will take place before the movie from 6-8:30pm.

Summer Camp

Summer camp concluded on Thursday, August 8th. We received 87 parent's evaluations with overwhelming positive feedback, official results to be tallied soon. There were seven Leaders in Training graduates who will successfully move on to Junior Staff next summer. Bonus week started on August 12th with 30 participants enrolled, campers will be ice skating and going to The Farm.

Brooklyn Park Dance

Dance has an instructor meeting on August 21st where there will be promotion video created with past dancers to invite new participants to join this season. The Open House and Shoe Sale is on September 5th with the first day of classes slated for September 16th.

Zanewood Programming

Zanewood Recreation Center offers recreation and youth development programs in a safe and positive environment for kids and teens. Zanewood also offers Outreach, community service, and youth mentoring opportunities delivered by committed and competent community partners.

Zanewood Programs for Grades 6-12

Teen Zone: Free, drop-in program, M-F from 2-8:00pm

ZW Teen open gym: Hoop IT UP! Monday & Wednesdays and Fridays from 6-8pm

Zanewood Meals program: Free, M-F from 2-5:00pm

TKO Drumline: Practices Tuesday & Thursday 6-8pm; performance schedule varies

Chess Club- June 8th- August 15th on Mondays and Friday's 4-6:00

Zanewood Music Studio- Tuesdays and Thursdays Starting July 22nd 4-6:00pm

Young Adult programming

Young Adult Open gym-Wednesday from 8:00- 10:00pm. \$3 BP resident/ \$5 non-resident

Arts, Wellness & Engagement Programming

Youth Wellness Journey – July 22- September 13th, register at Zanewood Recreation Center

K- 5th grade programming

Fusion Sites: 4:00- 6:00pm, Monday- Thursday at Zanewood Recreation Center - 7100 Zane Ave North.

➤ Session 3 April 1- June 6

Rec on the Go- September 9- December 20

At Huntington, Autumn Ridge, Park Haven Apartments

Ages: K-5

Rec on the Go is a FREE program that brings recreation opportunities to youth, K–5th grade, all-over Brooklyn Park. Kids must be 5 years old by June 1, 2024 and entering kindergarten to participate. Activities will include group games, team-building challenges, sports, arts and crafts, and science. Meals and snack will be provided

Primary Issues/Alternatives to Consider: N/A

Budgetary/Fiscal Issues: N/A

Attachments:

8.1A 2024 Summer Events Schedule



brooklynpark.org/celebrate

Celebrate Brooklyn Park

2024 Events



WEDNESDAYS JULY 10 - OCT 9 1 P.M. - 6 P.M.	Farmers Market North Hennepin Community College
JULY 12 5 PM - 7 PM	Summer Splash Zanewood Rec Center, 7100 Zane Ave N
JULY 19 5 PM - 9 PM	Jazz in July Community Activity Center, 5600 85th Ave N
AUG 2 7 PM - 11 PM	Kick-off to National Night Out Central Park, 8440 Regent Ave N
AUG 3 11 AM - 2 PM	Sounds of Asia Concert River Park, 2 83rd Ave N
AUG 17 11 AM - 3 PM	Back to School BBQ Zanewood Rec Center, 7100 Zane Ave N
SEP 7 2 PM - 3:30 PM	Pick-Up Truck Opera: Faust North Hennepin Community College
SEP 14 11 AM - 12:30 PM	Salsa del Soul Concert Community Activity Center, 5600 85th Ave N
SEP 21 4 PM - 7 PM	September Soul Arts & Music Fest Zanewood Rec Center, 7100 Zane Ave N
OCT 11 5 PM - 7 PM	Latino Fest Community Activity Center, 5600 85th Ave N
OCT 26 2 PM - 5 PM	Spooktacular Zanewood Rec Center, 7100 Zane Ave N

If you need this information in another language or format or disability accommodations, email access@brooklynpark.org or call 763-493-8000.

Si usted necesita esta información en español: 763-493-8000.

Yog xav tau kev pab, thov hu rau 763-493-8000 lawv mam li nrhiav ib tus neeg txhais lus rau koj.

Brooklyn Park
Unique. Unifed. Undiscovered.

Celebrate!
Brooklyn Park

Learn More



brooklynpark.org/eidemfarm/

Historic 2024 Events Eidem Farm

4345 101st Ave N, Brooklyn Park MN

Open Gate | May 20 – October 19

*Hours are subject to change due to specific events or rentals

*Adjusted times will be posted on the Historic Eidem Farm Facebook page

Monday/Wednesday 10 am - 4 pm	Tuesday/Thursday 10 am - 7 pm	Saturday 10 am - 3 pm
----------------------------------	----------------------------------	--------------------------



MAY 18 11 AM - 2 PM	Spring on the Farm
TUESDAYS 11 AM	Stories from the Porch May 21 - October 15
JUNE 27 6 PM	The Teddy Bear Band Family Concert
JULY 11 6 PM	Sticks & Tones Family Concert
JULY 25 6 PM	Mary Hall's Show for Pipsqueeks Family Concert
AUG 8 6 PM	The Brooklyn Community Band Concert
AUG 23 6 PM - 10:30 PM	Happy Hour & Movie Drinks by Heavy Rotation Brewery 6 - 9 PM Movie: The Wedding Singer at Dusk
AUG 29 6 PM - 10:30 PM	Family Fun & Movie Farm Activities from 6 PM - 8:30 PM Movie: Babe at Dusk
SEP 13 5 PM - 9 PM	Happy Hour & Concert Drinks by Heavy Rotation Brewery 5:30-8:30 pm Music by Pirate, Guitairs, and Beachfront Bars
OCT 5 12 PM - 3 PM	Fall on the Farm
DEC 7 12 PM - 3 PM	An Eidem Farm Christmas

If you need this information in another language or format or disability accommodations, email access@brooklynpark.org or call 763-493-8000.

Si usted necesita esta información en español: 763-493-8000.

Yog xav tau kev pab, thov hu rau 763-493-8000 lawv mam li nrhiav ib tus neeg txhais lus rau koj.

Brooklyn Park
Unique. Unified. Undiscovered.



City of Brooklyn Park Recreation and Parks Advisory Commission

Agenda Item:	8.2	Meeting Date:	August 21, 2024
Agenda Section:	Written Reports	Presented By:	Marcus Hill, Facilities and Parks Manager Greg Hoag, Parks & Building Maintenance Manager
Recreation & Parks Director Proposed Action	Park Project Updates		

Overview:

1. MISSISSIPPI GATEWAY REGIONAL PARK / ENVIRONMENTAL NATURE AREA

Funding Source(s): OSLAD Fund

Project Update:

Development of the Brooklyn Park side of the park includes expansion of the off-leash dog area, relocation of the archery range, addition of a large picnic shelter and restroom facilities along with an expanded parking area is anticipated to begin in the spring of 2023.

Construction began on April 17, 2023. Construction of the maintenance facility is complete. The work on the Gateway Center is moving along quickly. The building is almost fully enclosed. Construction is nearly complete on the reservation shelter on the west unit. The Dog Park has been relocated to the north end of the park near the water tower and work is moving along on the dog park fencing and trails. The curbing for the parking lot and the playground on the west unit are in place. Work on the playground is nearing completion.

2. EAB UPDATE

Funding Source(s): Heritage Fund

Project Update: Work will continue in 2024. The city received the 2023-2024 Healthy Tree Canopy Grant from Hennepin County for \$50,000. This Grant will continue to assist in the removal and re-planting of trees. The city also received a \$498,840 Bonding Grant from the DNR. This grant will focus on removal and replacement of boulevard trees. The city recently received the 2024-2025 Healthy Tree Canopy Grant from Hennepin County for \$50,000. These funds will be for updated work on the tree inventory and to purchase additional replacement trees.

3. NATURAL RESOURCE MANAGEMENT

Funding Source(s): Park Bond Reinvestment Project & Heritage Fund

Project Update: Staff continues reviewing priorities of the Natural Resource Management Plan. A Five-Year Priority Implementation Plan has been developed by working with Stantec. Work will continue in 2024 in key park areas.

4. **COMMUNITY ACTIVITY CENTER IMPROVEMENTS
(2025 planning, 2025-2026 construction)**

Funding Source(s): Park Bond Reinvestment Projects

- **COMMUNITY ACTIVITY CENTER**

Project Overview: The plan is to improve the entrance to the facility, create an accessible customer service desk, update bathrooms, and create a welcoming and inviting community center for all customers.

Staff worked with the JLG/292 Design Group to evaluate the possibility of converting one ice arena into three basketball courts. A final concept design was provided to staff in January and refined in February. JLG/292 Design Group provided cost estimates in the range of \$12 - \$15 million for the improvements to the CAC including improved entrances, informal gathering space, relocated office space, improved parking and possible Arena conversion to gym space. The City of Brooklyn Park was awarded \$5 million in state bonding funds during the 2023 Legislative Session to support the improvements to the Community Activity Center. This language was amended in the 2024 legislative session to remove language about the conversion of rink one.

Project Update: The City of Brooklyn Park submitted a \$12M request for MN State Bonding to create additional court space at the CAC. The Legislature did not pass a bonding bill in 2024, so this project remains on hold. Staff have worked with Ballard-King to develop a needs assessment survey to gauge the current and future facility needs for ice and court users in Brooklyn Park. Staff plan to bring discussion back to City Council to begin planning for the addition of courts at the CAC this Fall.

- **SENIOR CENTER (2025 planning, 2026 construction)**

Project Overview: This improvement would add dedicated space for senior programming and adult fitness space. Final design and components will be developed when a final location is determined. The Senior Center is being considered with the CAC improvements and Fire Station projects. A new Central Fire station is planned to be constructed on the site of the former Hennepin County Library. If that happens, the current Central Fire Station is planned to be remodeled into a new space dedicated to fitness and social activities for older adults.

Project Update: No New Update

5. **TEEN CENTER (2023 planning, 2024-25 construction)**

Project Overview: The Zanewood Recreation Center has been a popular hub for youth services and recreation activities. The programming happening in the space has outgrown the facility and additional program space is needed. Staff will work with a design consultant (Design by Melo) to determine if new space should be constructed, existing space should be renovated, or a combination of both.

Project Update:

Phase 2 is complete of the Design Development of the Brooklyn Park Teen Center. Staff has spent the last 14 months finalizing the footprint and floor plan of the new teen center and the existing space. The spaces that we have expanded are Teen game lounge, Teen commons area, Art space, Best Buy tech lab space, and outdoor programming space, indoor and outdoor gym. July 8th, the City Council voted 6-0 in favor of reallocating Park Bond funds to fund the overall project. We are estimating that the total project cost will be roughly \$10 million dollars.

Phase 3 has been accepted by the city council and that will be for construction documents and drafting an RFP. We unfortunately, were not awarded any state bonding funds, but are continuing to apply for grants and will have a million-dollar request to the Minnesota Timberwolves and Lynx Fastbreak foundation and Peter J King Family foundation.

Teen Center is currently out to bid and the deadline for submissions will be August 20th. The next steps will be to interview candidates and award the bid. Once the bid is awarded, we hope to start construction early fall with project completion of summer of 2025.

TRAILS, WAYFINDING AND LIGHTING

Funding Source(s): Park Bond Reinvestment Projects

Project Update: Staff in Recreation & Parks have partnered with Community Development staff to implement the first phase of the Trails Wayfinding Plan developed by AVIA Design. The Wayfinding Project will provide signage and direction and key intersections and points of interest along the trails in Brooklyn Park. The project was awarded to SignArt and installation is taking place into the early Fall.

6. PLAYGROUND REPLACEMENT

Funding Source(s): Heritage Fund

Project Update: On August 28, 2023 City Council approved the City Park playground replacement project. Installation was completed at the end of June. Pinebrook Park recently had a new 2-5 playground structure installed by city staff. The old playground was removed in 2022 due to safety concerns.

7. TRAIL REHABILITATION

Funding Source(s): Heritage Fund

Project Update: As part of the trail rehabilitation project the trail on the west side of Jefferson Highway is getting rehabilitated. The section from 109th to 101st Avenue was completed in mid-November. In July of 2024 a mill and overlay of the trail south from 101st Avenue to 93rd Avenue along Jefferson Highway was completed. In late August staff will be rehabilitating the trails in Tessman Acres Park.

8. HISTORIC EIDEM FARM VISITOR CENTER (TDB planning, TBD construction)

Funding Source(s): Park Bond Reinvestment Projects

Project Update: No new update

9. PARKING LOT REHABILITATION

Funding Source(s): Heritage Fund

Project Update: As part of the 2024 Street Rehabilitation project the parking lots at Central Park and the Brookdale dog park area were rehabilitated. This work was completed in July.

Primary Issues/Alternatives to Consider: N/A

Budgetary/Fiscal Issues: N/A

Attachments:

CITY OF BROOKLYN PARK RECREATION AND PARKS ADVISORY COMMISSION			
Agenda Item:	8.3	Meeting Date:	August 21, 2024
Agenda Section:	Written Reports	Presented By:	Brad Tullberg, Director of Recreation and Parks
Recreation & Parks Director Proposed Action	Directors Report		

Overview:

1. 2025 Annual Budget

Brooklyn Park staff are working to develop the annual budget for 2025. More information will be provided in September about the Recreation and Parks Department annual budget.

2. Summer Programming

August 8th was the last full day of summer programming for the Recreation and Parks Department. This marked the last day of camp, swimming lessons and Fusion. However, many programs continue to operate throughout the year. Participation numbers were very good in 2024.

3. Teen Center Bidding

The Teen Center project was advertised for proposals on July 26th. Proposals are due on Tuesday August 20th. If the project is within budget staff hope to bring the project to City Council for approval at the September 9th meeting.

4. Edinburgh RFP

The Restaurant Management Services RFP was released for advertisement on June 27. A total of five proposals were received by the August 7th deadline. A committee of staff will review the proposals and interview two or three potential teams to provide Restaurant, Beverage Cart and Alcohol Catering Services at Edinburgh Clubhouse.

5. Central Fire and CAC traffic planning

The Central Fire station took another step forward in the planning process when City Council gave design feedback about what should be included in a new Central Fire Station. One of the next steps is to do a traffic study of Zane Avenue, 85th Avenue and Edinbrook Terrace traffic to determine the safest access for emergency vehicles to enter traffic. This traffic study will also look at possible scenarios for the CAC improvements and best ways to manage traffic in and out of the facility

6. Wayfinding Installation

Staff have received several positive comments about the trail wayfinding being installed on trails in Brooklyn Park. Signage is being installed at high use trail locations and intersections of primary trail connections. Secondary trail connections and pavement marking will be installed later this year.

Attachments: